

Veritas Storage Foundation™ for Oracle® RAC from Symantec

Manageability and availability for Oracle® RAC databases

Overview

Veritas Storage Foundation™ for Oracle® RAC from Symantec offers a proven solution to help customers implement and manage highly available Real Application Clusters (RAC) databases. The solution leverages Symantec’s industry-leading Veritas Storage Foundation™, Veritas Storage Foundation™ Cluster File System, and Veritas Cluster Server™ products, and has been tightly integrated with Oracle RAC to provide a reliable, easy-to-use storage and cluster management solution. Storage Foundation for Oracle RAC enables IT organizations to select the most appropriate operating system and storage hardware for their environment, all without compromising management capabilities.

Storage Foundation for Oracle RAC provides a single management view for all database, clustering and storage management tasks, enabling IT organizations to install, configure and manage centrally independent of hardware platform. Moreover, it increases flexibility, scalability and performance while reducing system downtime.

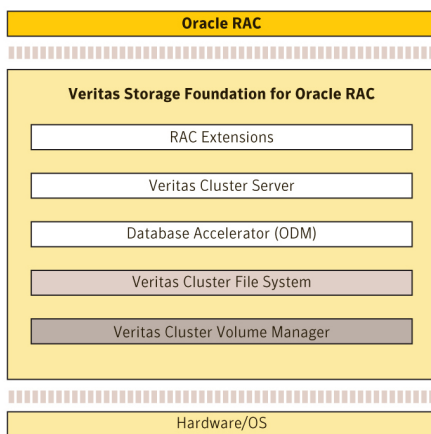

Figure 1. Storage Foundation for Oracle RAC architecture

Highlights

- **Simplify management of Oracle RAC**—Centralize multi-node management and make RAC as easy to manage as a single-node non-RAC database
- **Facilitate off-host processing**—Create easy-to-use database clones to enable data analysis and backups
- **Increase efficiency of database backup and recovery**—Protect the database from logical errors by providing point-in-time copies
- **Ensure data integrity**—Eliminate the risk of data corruption in the event of a “split brain” condition
- **Identify and remove I/O bottlenecks**—Map database objects down the storage hierarchy to the disks
- **Scalable database performance**—Utilize database accelerators and multiple physical paths to disks
- **Enable stretch RAC environments**—Achieve high availability and disaster recovery by utilizing a campus cluster configuration for Oracle RAC
- **Reduce database storage costs**—Automatically move less frequently used data to slower, less expensive disks

Simplify management of Oracle RAC

While most application cluster implementations are intended to increase application availability, Oracle RAC also attempts to improve application scalability by using multiple servers for the same workload. However, this scale-out approach to clustering introduces management complexity to server, storage and database administration. Veritas Storage Foundation for Oracle RAC minimizes this complexity by enhancing the native capabilities of Oracle

RAC with a highly available, scalable, non-disruptive server and storage management solution that is independent of operating system and storage hardware. The centralized management capability of Veritas Storage Foundation for Oracle RAC enables users to add and remove nodes and storage capacity without impacting application availability. Veritas Cluster File System enables Oracle RAC tablespaces to grow online without the need to pre-allocate storage capacity. A single cluster file system and volume management tool facilitates creation of a shared Oracle home that simplifies ongoing maintenance and patch management.

Facilitate off-host processing

Relational databases provide a single view of the data to all applications referencing it. While this dramatically improves the quality of information available to users and managers, it constrains an enterprise's ability to use the same data for data analysis or backup. Both require point-in-time images, which cannot be made while a database is being updated by business applications. The Veritas Storage FlashSnap™ feature enables administrators to set up reusable point-in-time copy policies, verify storage resources, and create full online database volume clones and space-saving file system checkpoints with minimal impact on production applications and users. Database snapshots can be migrated to secondary servers and used for resource-intensive processes such as backups, decision support, reporting, and testing—independent of the storage hardware being used.

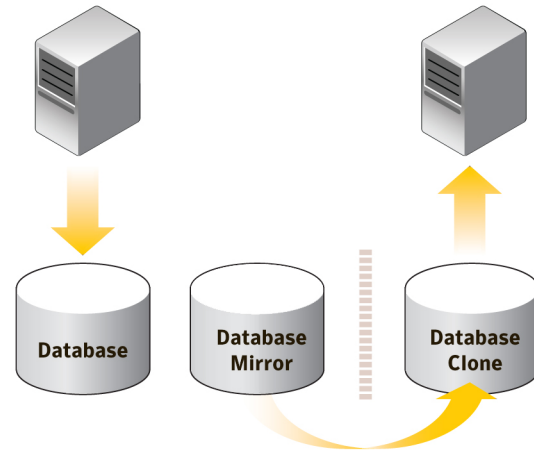

Figure 2. Migrating database snapshots to secondary servers

Increase efficiency of database backup and recovery

Veritas Storage Foundation for Oracle RAC enables efficient backup and recovery of Oracle RAC databases using Storage Checkpoint technology. Storage Checkpoint is a disk- and I/O-efficient snapshot technology for creating a “clone” of a currently mounted file system (the primary file system). Unlike a full file system copy that uses separate disk space, all Storage Checkpoints share the same free space pool where the primary file system resides, greatly reducing the need for extra storage. A direct application of the Storage Checkpoint facility is Storage Rollback. Because each Storage Checkpoint is a consistent, point-in-time image of a file system, Storage Rollback is the restore facility for these on-disk backups. Storage Rollback simply rolls back blocks contained in a Storage Checkpoint into the primary file system for very fast database recovery.

Ensure data integrity

When multiple systems/nodes have access to data via shared storage, the integrity of the data depends on

internode communication ensuring that each node is aware when other nodes are writing data. When the coordination between the nodes fails, it results in a “split brain” condition—a situation in which two servers try to independently control the storage, potentially resulting in application failure or even corruption of critical data, which can then require days to recover, if recovery is even possible.

I/O fencing is Symantec’s method of choice for ensuring the integrity of critical information by preventing data corruption. Veritas Storage Foundation for Oracle RAC has implemented I/O fencing using the industry standard SCSI-3 persistent group reservation technology, allowing a set of systems to have temporary registrations with the disk and coordinate a write-exclusive reservation with the disk containing the data. With I/O fencing, Symantec ensures that errant nodes are “fenced” and do not have access to the shared storage, while the eligible node(s) continue to have access to the data, virtually eliminating the risk of data corruption.

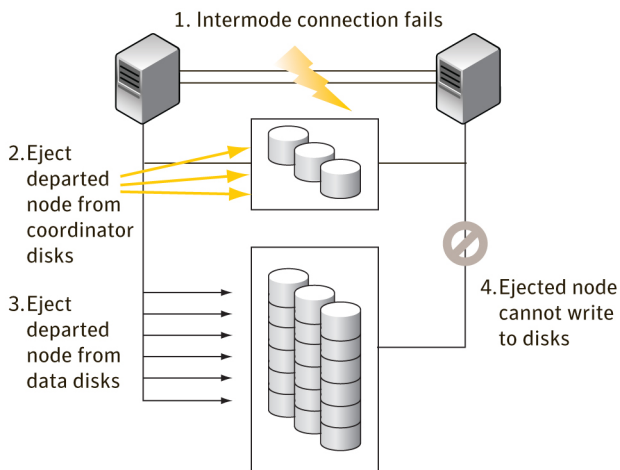

Figure 3. Implementing I/O fencing

Scalable database performance

There is a strong movement towards the consolidation of multiple disparate database systems onto even larger RAC clusters. The major concern in any consolidation effort is maintaining respectable performance and/or meeting committed performance service-level agreements (SLAs). Veritas Storage Foundation for Oracle RAC improves the overall performance of database environments by providing extensions to Oracle Disk Manager (ODM), a database accelerator technology that enables OLTP performance equal to raw disk partitions, but with the manageability benefits of a file system. It delivers the same performance benefits as Veritas Quick I/O, but also provides tight database integration for easier manageability. Moreover, with the Dynamic Multi-pathing feature of Veritas Storage Foundation for Oracle RAC, performance is maximized by load-balancing I/O activity across all available paths, from the server to all major hardware RAID array products. Moreover, with this feature, there is no need for third-party multi-pathing software, reducing the total cost of ownership.

Identify and remove I/O bottlenecks

The challenge with maximizing database performance is having visibility from the data file to the storage spindle. The storage mapping feature in Veritas Storage Foundation for Oracle RAC provides organizations with a proven approach to that visibility, when used with Veritas Storage Foundation Manager. When organizations have detailed database mapping information, a detailed understanding of the storage hierarchy, and knowledge of where each data file resides, performance bottlenecks can be eliminated. Armed with this information, IT

organizations can minimize I/O performance bottlenecks by dynamically moving data files to different logical units on different physical spindles, or to another array altogether. The performance tuning capabilities of Storage Foundation for Oracle RAC gives organizations the flexibility to be as sophisticated as they choose, or let Storage Foundation manage data architecture with hot relocation, a feature that automatically detects and replaces failed disks using a free disk pool.

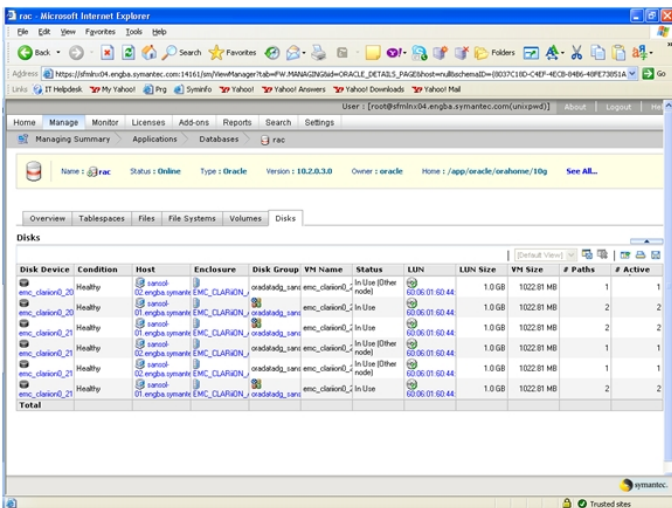

Figure 4. Gain visibility with Veritas Storage Foundation Manager

Enable stretch RAC environments

A campus cluster configuration provides local high availability and disaster recovery capability in a single Storage Foundation for Oracle RAC cluster. This configuration uses data mirroring to duplicate data at different sites. No host or array replication is involved in the process. Storage Foundation for Oracle RAC supports campus clusters that employ shared disk groups mirrored with Cluster Volume Manager (CVM).

A Storage Foundation for Oracle RAC campus cluster is

similar to a basic Storage Foundation for Oracle RAC cluster except that the data is mirrored across multiple sites. When a site fails, the Storage Foundation for Oracle RAC cluster in the secondary site continues running and as parallel applications are already running on the secondary nodes, they are not affected. The ability to run RAC in a campus cluster configuration results in a more highly available disaster recovery environment. Using a Coordination Point Server (CPS) in a campus cluster environment enables the use of a 3rd site as an arbitration point without requiring SAN connectivity to the 3rd site.

Reduce database storage costs

As the size of a relational database grows, so does the size of the inactive data. The result: a steep rise in storage costs and an abysmal drop in database performance. The Database Dynamic Storage Tiering feature of Veritas Storage Foundation for Oracle RAC matches data storage with the data's usage requirements so that data is relocated to less expensive storage based on policies defined by the administrator. Policies can be created that will move data based on partition name, log files or database files. The key benefit of this capability is that less-frequently used data is created on or automatically moved to slower, less expensive disks, allowing frequently-accessed data to be stored on the faster disks for quicker retrieval. Moreover, data file creation or movement can occur without taking the database offline and can be completely transparent to users and applications.

Other Product Highlights

- **Storage capacity planning**—Simulate various Storage

Checkpoint creation and retention models in a production environment

- **Flexible management**—Offer intuitive Web or command line interface options for local or remote management
- **Intelligent workload management**—Increase automation of cluster administration, maximize application uptime, and improve utilization of server resources
- **Cluster-wide logical device naming**—Simplify management of SAN-based storage
- **Support for Oracle Enterprise Manager Grid Control**—Monitor Veritas Cluster Server, raise alerts and violations based on resource stack and map database objects on the Symantec storage stack

Related products

- **Veritas Storage Foundation™ Cluster File System**—All the features of Storage Foundation plus a cluster file system and cluster volume manager for concurrent data access from multiple servers
- **Veritas Cluster Server™**—Monitors the status of applications and automatically moves them to another server in the event of planned or unplanned outages

Supported operating systems

- IBM® AIX®
- Sun™ Solaris™
- HP-UX®
- Red Hat® Linux
- SUSE® Linux
- Oracle® Enterprise Linux

More information

Visit our website

<http://enterprise.symantec.com>

To speak with a Product Specialist in the U.S.

Call toll-free 1 (800) 745 6054

To speak with a Product Specialist outside the U.S.

For specific country offices and contact numbers, please visit our website.

About Symantec

Symantec is a global leader in providing security, storage and systems management solutions to help consumers and organizations secure and manage their information-driven world. Our software and services protect against more risks at more points, more completely and efficiently, enabling confidence wherever information is used or stored.

Symantec World Headquarters

350 Ellis St.

Mountain View, CA 94043 USA

+1 (650) 527 8000

1 (800) 721 3934

www.symantec.com

Confidence in a connected world.

